



Frollini

g. 700





Frollini

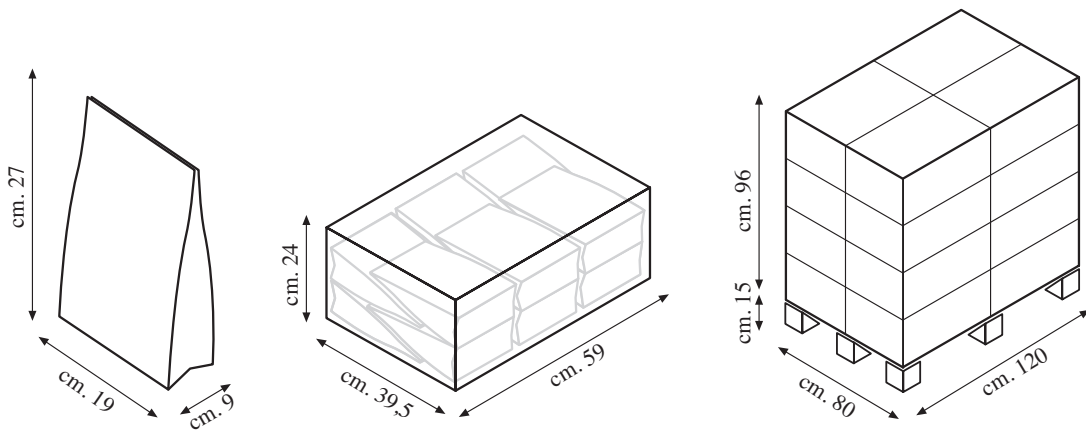

CODICE AZIENDALE - ITEM N.	0216	0217	0218	0219	0220	0221
CODICE EAN - EAN CODE	8008910021605	8008910021704	8008910021803	8008910021902	800891002008	8008910022107
DENOMINAZIONE ARTICOLO ARTICLE DENOMINATION	FROLLINI ALLA PANNA	FROLLINI CON FARINA DI RISO	FROLLINI CON GOCCE DI CIOCC.	FROLLINI AL CACAO E NOCC.	FROLLINI CON GRANA SARACENO	FROLLINI CON GRAN. ZUCCH.
PESO NETTO NETWEIGHT	g			OZ		
	700			24,69		
PEZZI PER CARTONE PIECES IN EACH CARTON	12					
PESO LORDO CARTONE CARTON GROSSWEIGHT	9.3 Kg - 20,5 lb					
CUBATURA CARTONE - CARTON CUBAGE	0,028 m ³					
CARTONI PER PALLET CARTONS PER PALLET	16					
CARTONI PER PALLET A TERRA CARTONS PER PALLET (STACKED PALLET)	32 (di cui 16+16)					
SCADENZA - SHELF LIFE	16 mesi - months					

Norme di conservazione: Conservare in luogo fresco e asciutto - Preservation rules: Keep in a cool and dry place



Quality Food Group S.p.A. - Via Spilimbergo 221 - 33035 Martignacco (UD) - ITALY
 tel: +39 0432 638811 - fax: +39 0432 677152
 e-mail: info@qualityfoodgroup.com - web: www.qualityfoodgroup.com