

# Crackers



# Crackers

## Salati in superficie - Non salati in superficie - Integrali Olio extra vergine d'oliva e rosmarino

I classici rompidigiuno da portare ovunque e da sgranocchiare in ogni momento della giornata, anche come ottima alternativa al pane.

I crackers Delser sono preparati con ingredienti sani e genuini, salati in superficie, non salati in superficie, integrali e all'olio extra vergine d'oliva e rosmarino divisi in comodi pacchetti.

*Convenient individually wrapped crackers that you can take anywhere. An excellent alternative to bread.*

*The Delser crackers are prepared with healthy and genuine ingredients, salted on the surface, whole wheat and unsalted on the surface and extra virgin olive oil and rosemary individually packed.*

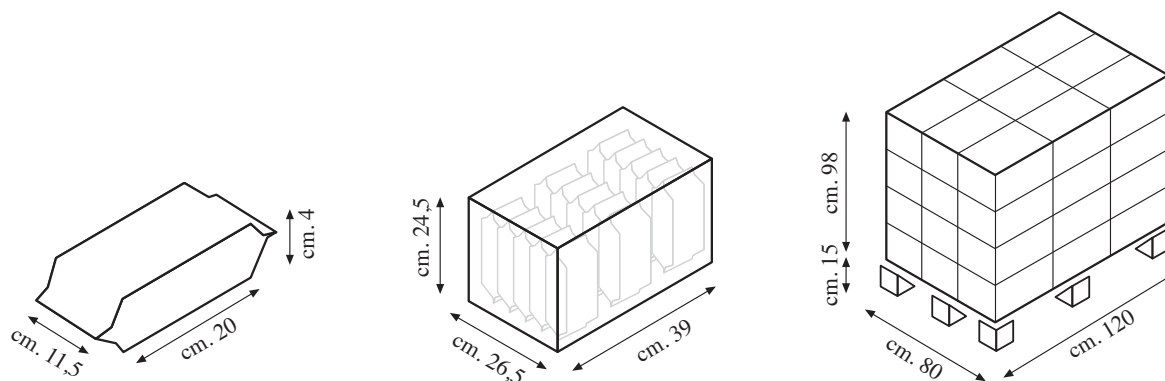

CODICE AZIENDALE - ITEM N.	0381	0434	0679	0676
CODICE EAN - EAN CODE	8008910803812	8008910804345	8008910806721	8008910806769
DENOMINAZIONE ARTICOLO ARTICLE DENOMINATION	CRACKERS SALATI	CRACKERS NON SALATI	CRACKERS INTEGRALI	CRACKERS OLIO ROSMARINO
PESO NETTO NET WEIGHT	g 200		OZ 7,05	
PEZZI PER CARTONE PIECES PER CARTON	15			
PESO LORDO CARTONE CARTON GROSS WEIGHT	4,1 Kg - 9,04 lb			
CUBATURA CARTONE - CARTON CUBAGE	0,0254 m <sup>3</sup>			
CARTONI PER PALLET CARTONS PER PALLET	36			
CARTONI PER PALLET A TERRA CARTONS PER PALLET (STACKED PALLET)	72 (di cui 36+36)			
SCADENZA - SHELF LIFE	16 mesi - months			

Norme di conservazione: Conservare in luogo fresco e asciutto - Preservation rules: Keep in a cool and dry place



Quality Food Group S.p.A. - Via Spilimbergo 221 - 33035 Martignacco (UD) - ITALY  
tel: +39 0432 638811 - fax: +39 0432 677152  
e-mail: info@qualityfoodgroup.com - web: www.qualityfoodgroup.com